

406 X 120 – 860 A SERIES AXLE

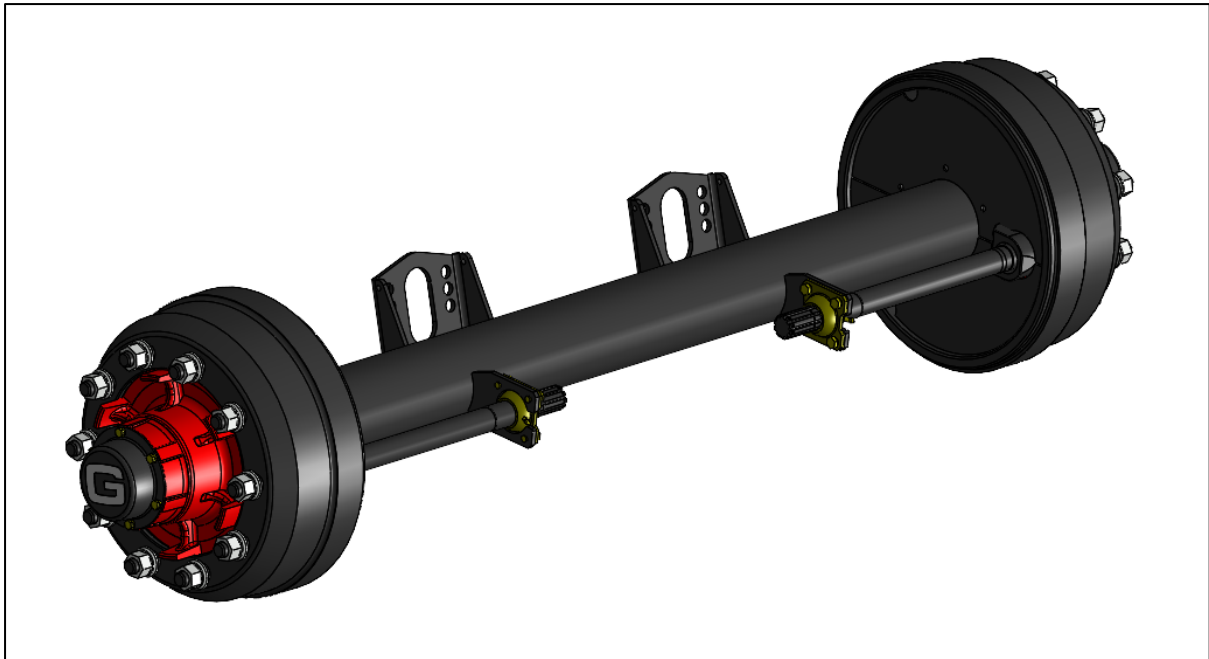

860 series axle is TUV tested to 10,000Kg, please see website for test report.

335mm PCD 10 stud M22 hub and drum. 281mm hub pilot.

Available in single and twin wheel stud.

10 spline camshaft

Service manual available on website

Please see following pages for part identification

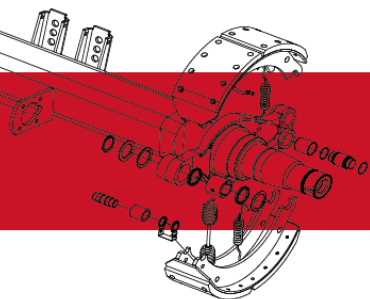

406 x 120 – 860 Series Quick Fit Brake Assembly

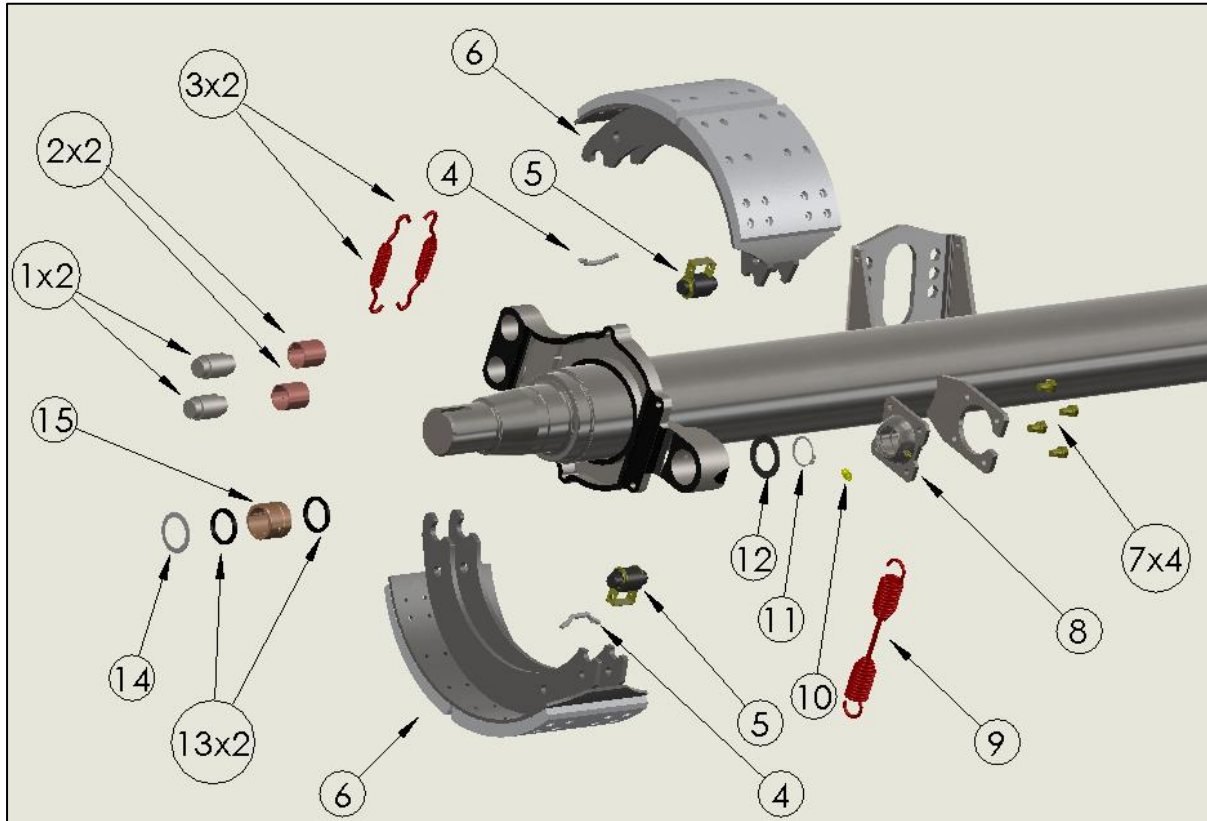

Item	Description	Part No.	QTY per Axle
1	Anchor Pin	61171	4
2	Bush Anchor Pin	61200B	4
3	Brake Shoe Retaining Spring	61141A	4
4	Spring Anchor Bar	61150	4
5	Retainer Cam Roller	61220	4
	One Piece Cam Roller	61235	4
6	Brake Shoe (AS120)	61159A	4
7	M10x 20 Screw	61359	8
	M10 spring washer	96363F	8
8	Camshaft Spherical Bearing	61080	2
9	Spring Return	61143	2
10	Greaser 1/8 NPT 45°	61110	2
11	Circlip	61120	2
12	Support Washer Camshaft	68159	2
13	Camshaft Grease Seal	61056	4
14	Washer Under Camshaft Head	61060	2
15	Camshaft Sintered Bush	61055	2

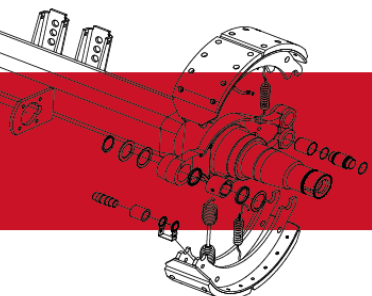

406 X 120 – 860 Series Hub/Drum Assembly

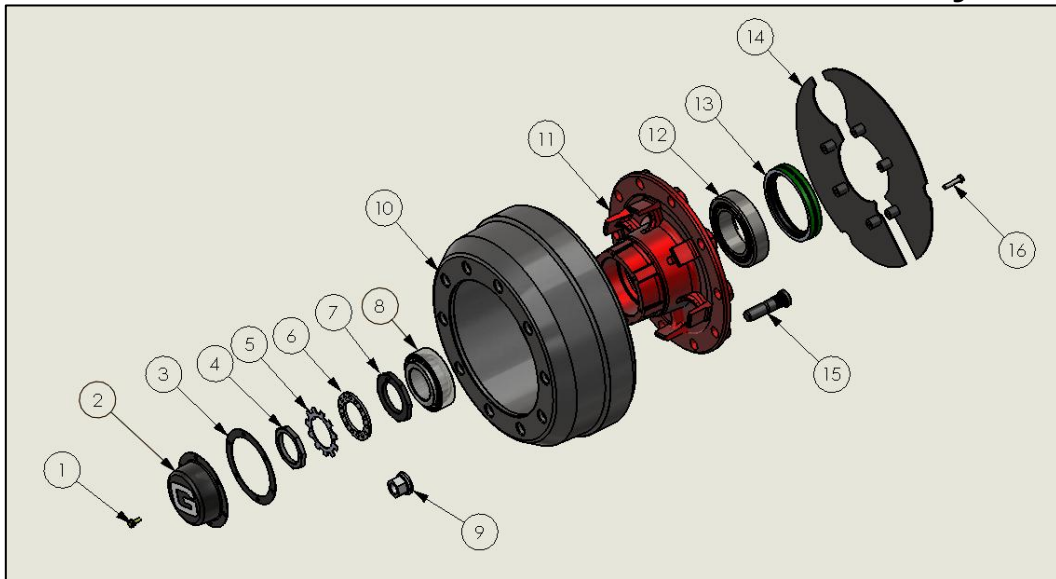

Item	Description	Part No.	QTY per Axle
1	Screw M8 x 16 Fl. Head	61358F	12
		61352	12
2	Hub Cap Pressing "G"	61322A	2
3	Gasket	61330A	2
4	Locknut	61310	2
5	Tab Washer	61311	2
6	Lock Washer	61300	2
7	Adjusting Nut	61290	2
8	Outer Bearing	61270F	2
9	ISO Wheel Nut M22	61381Z	20
		61383	(20)
		61411	(20)
		61372	(20)
		61371	(20)
10	Brake Drum 10 Stud	61550	2
11	Hub Spigot 10 Stud	61253	2
12	Inner Bearing	61260F	2
13	Unitised Grease Seal	61282	2
14	Dust Cover Round & Square Beam (2 piece)	61404A	12
		61396A	2
15	Wheel Bolt M22 ISO (Twin)	61386F	20
		61375	20
16	Screw M8 x 40	70914	12
		M8 washer	61352

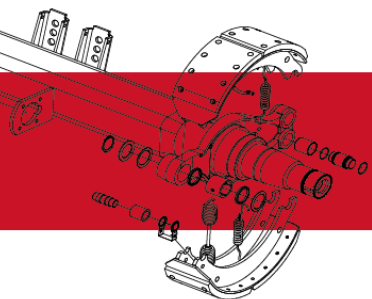

406 x 120 – 860 Series Camshaft Parts List

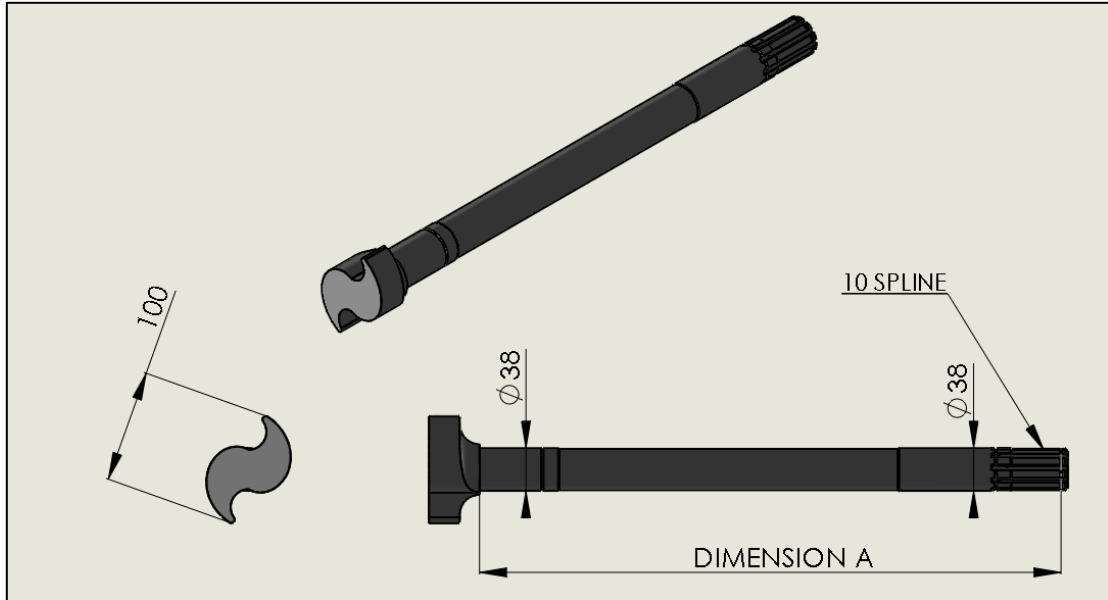

Item	Description (DIM A)	Part No.
1	Left Hand Large Head (519mm)	61065
2	Right Hand Large Head (519mm)	61075
3	Left Hand Large Head (618mm)	61067
4	Right Hand Large Head (618mm)	61077
5	Left Hand Large Head (189mm)	61127
6	Right Hand Large Head (189mm)	61147
7	Left Hand Large Head (212mm)	61061
8	Right Hand Large Head (212mm)	61071
9	Left Hand Large Head (250mm)	61138
10	Right Hand Large Head (250mm)	61148

Camshaft lengths are measured from under head to the centre of last circlip groove.

The illustrated camshaft is a right hand camshaft. When looking at the head of the camshaft a right hand cam is Z shaped and a left hand is S shaped

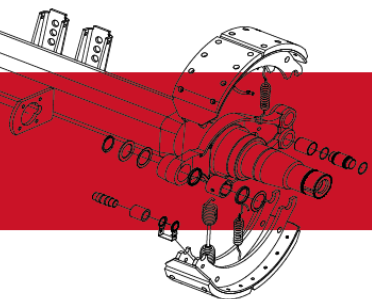

406 x 120 – 860 Series ABS/Anti-Lock Assembly

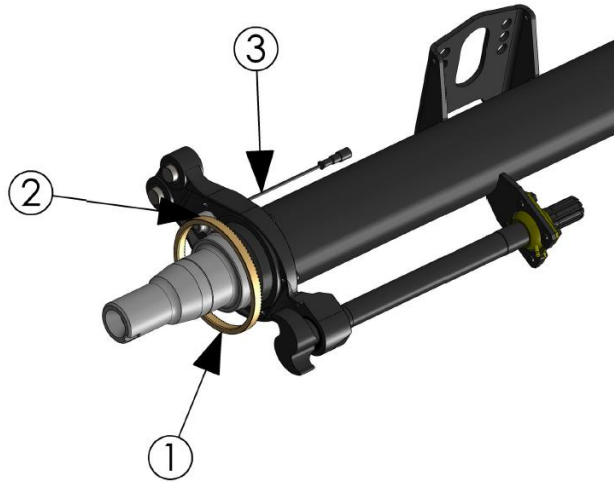

Item	Description	Part No.
1	Pole Wheel	61789
2	ABS Sensor Block	61781
3	ABS Sensor Bush	61792
4	Straight ABS Sensor Lead	61791

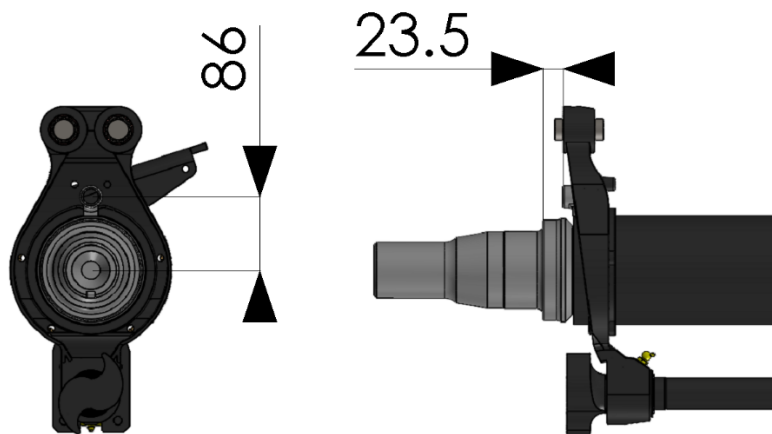

Pole wheel at 172mm PCD

Face of sensor block 23.5mm from large bearing shoulder

Weld on ABS block is 180 degrees to camshaft and is in line with hole in anchor bracket.

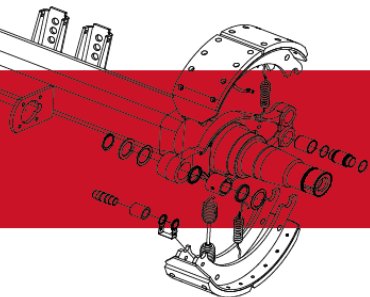

61171 – Anchor pin

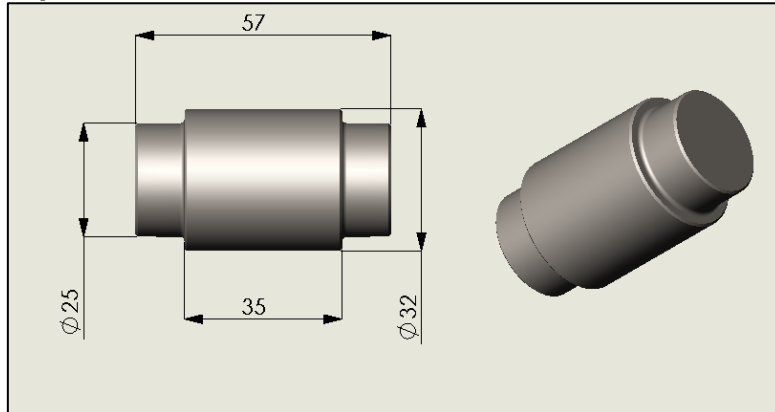

61200B – Bush Anchor Pin

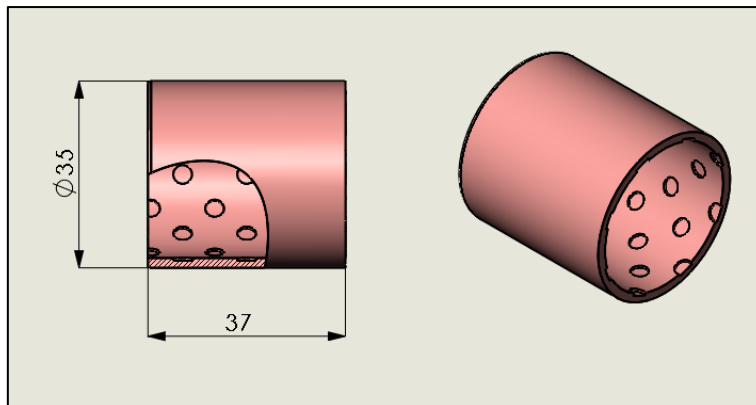

61141A – Brake Shoe Retaining Spring

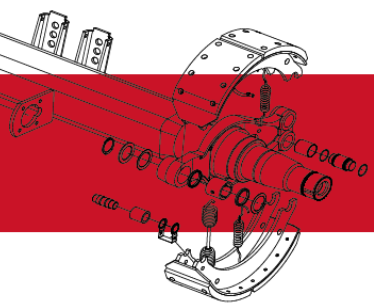
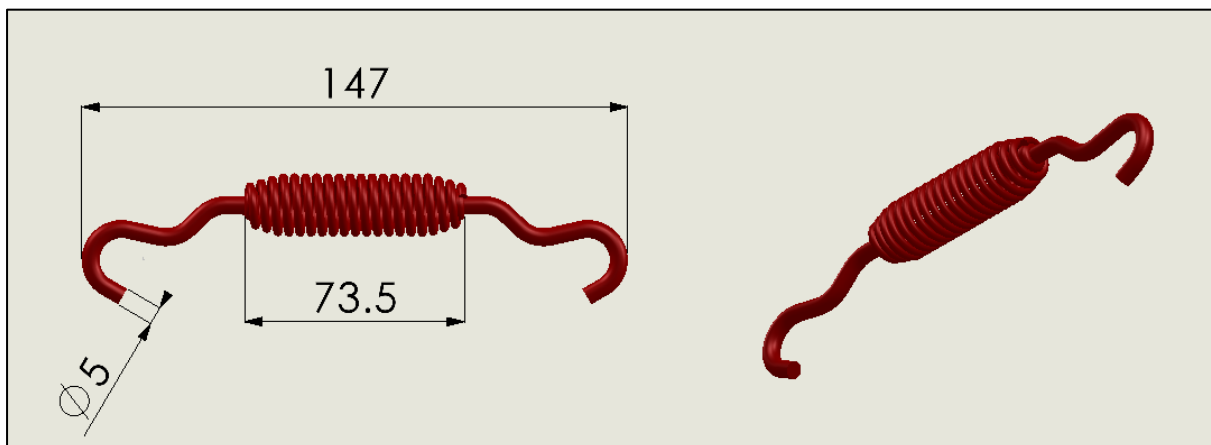

61150 – Spring Anchor Bar

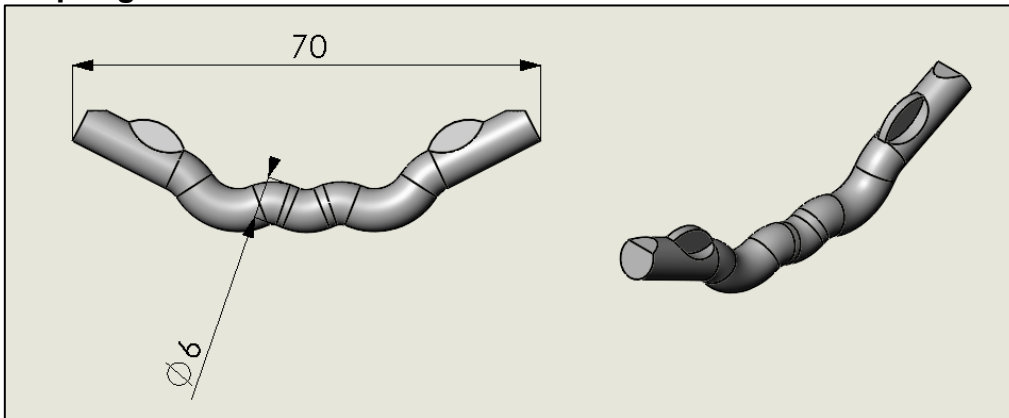

61220 – Retainer Cam Roller

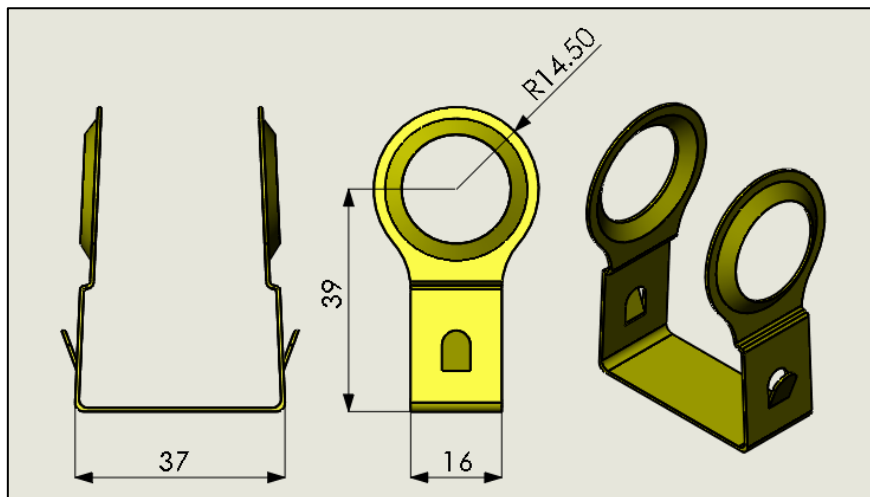

61235 – One Piece Cam Roller

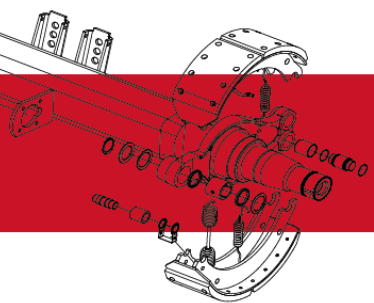
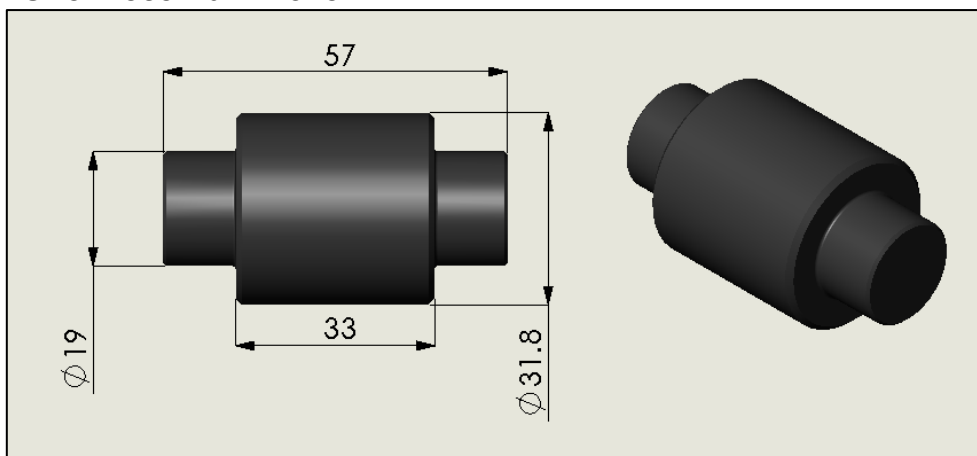

61159A – Brake shoe (AS120 DB4012C)

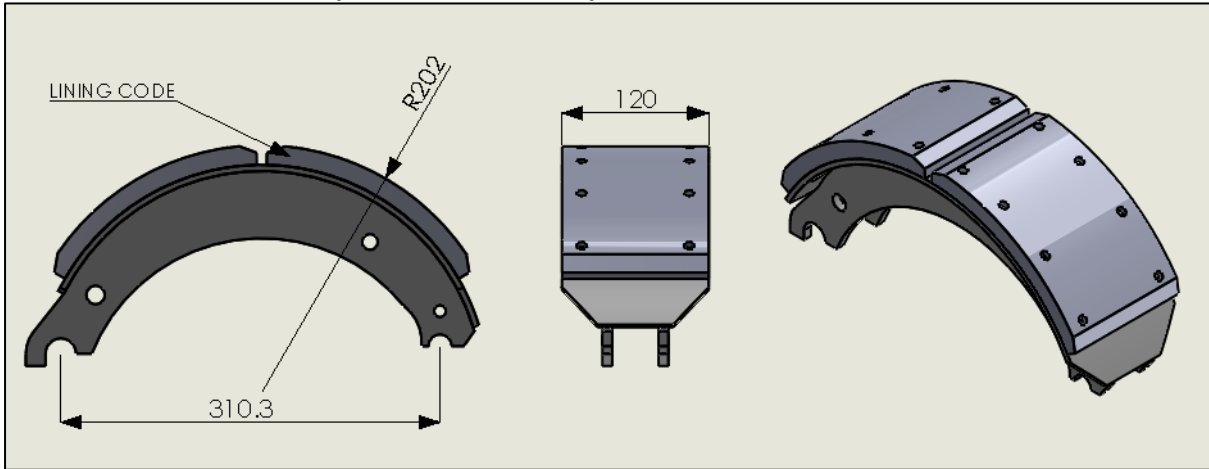

61080F – Camshaft Spherical Bearing

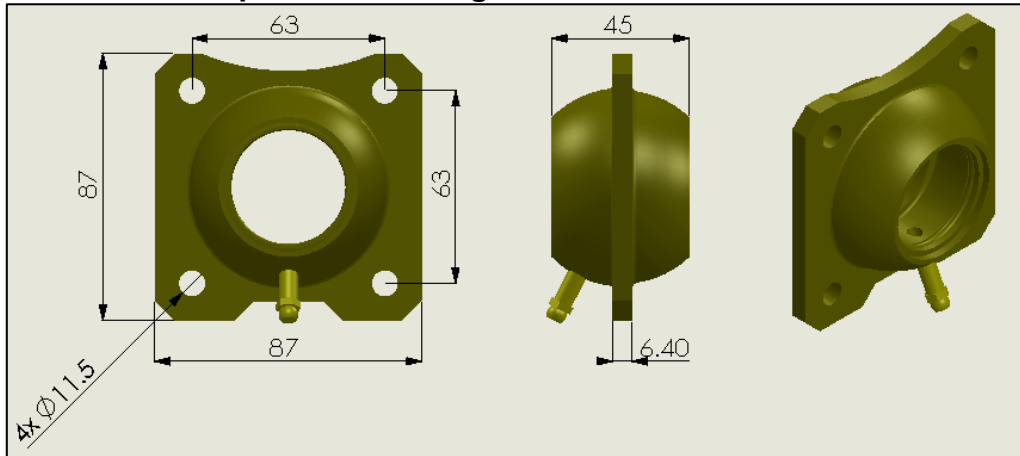

61143 – Spring Return

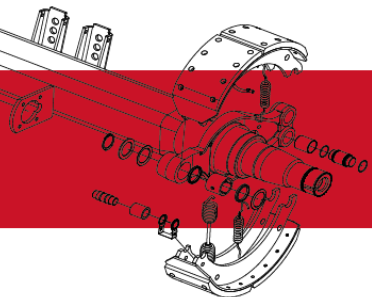
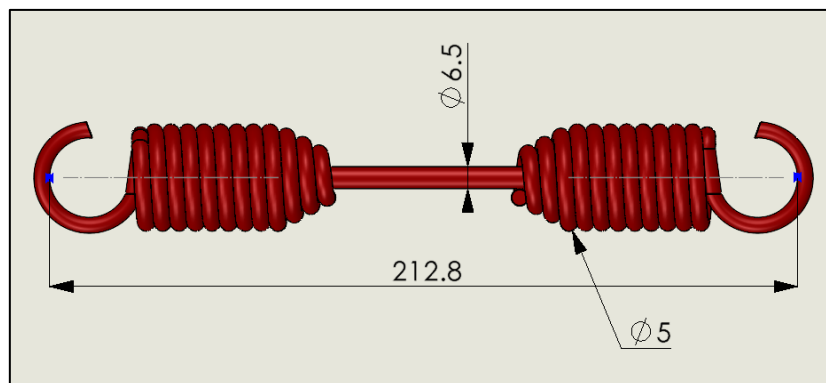

61120 – Circlip

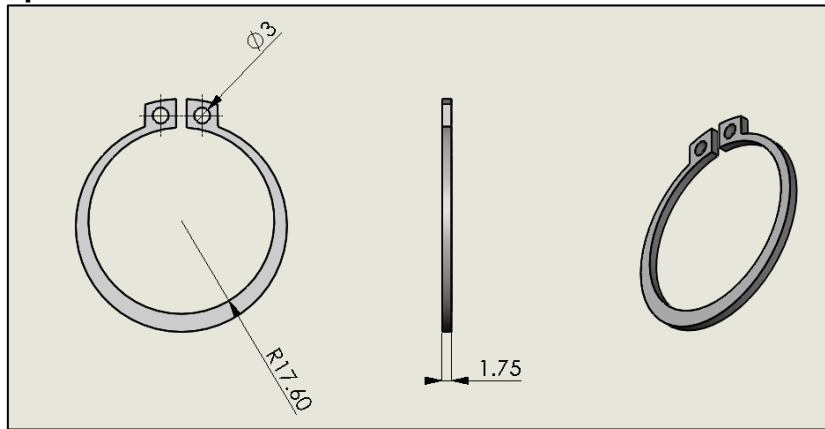

68159 – Camshaft Support Washer

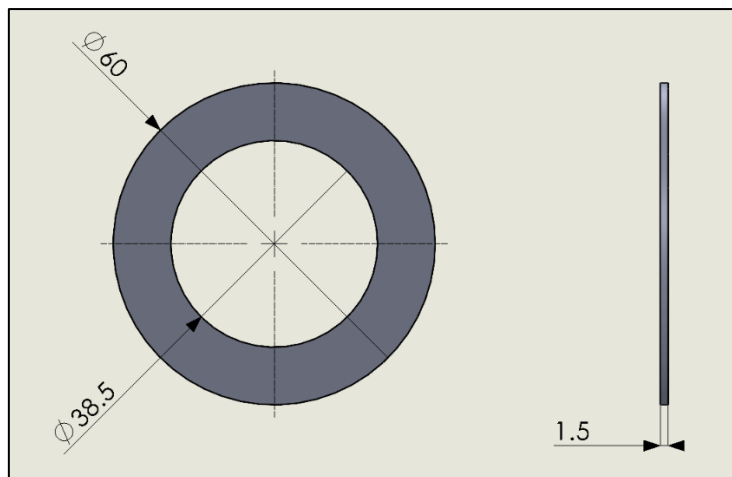

61056 – Camshaft Grease Seal

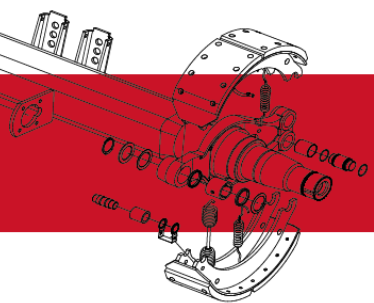
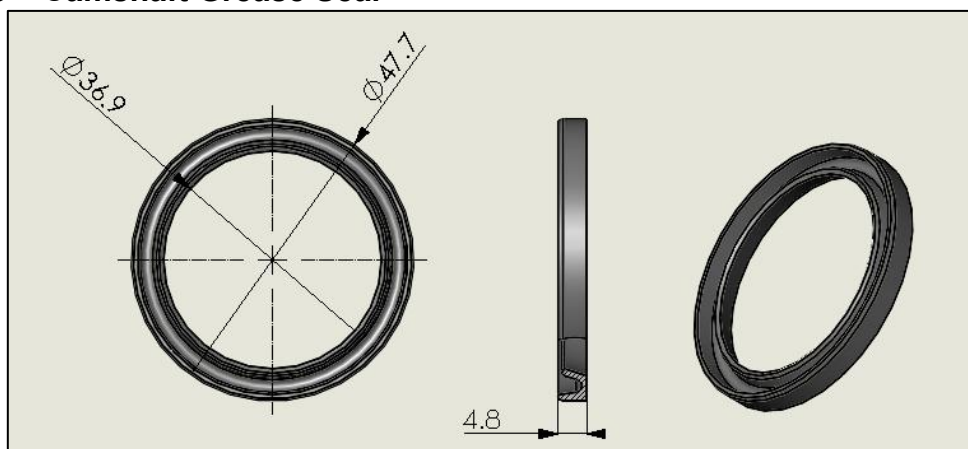

61060 – Washer Under Camshaft Head

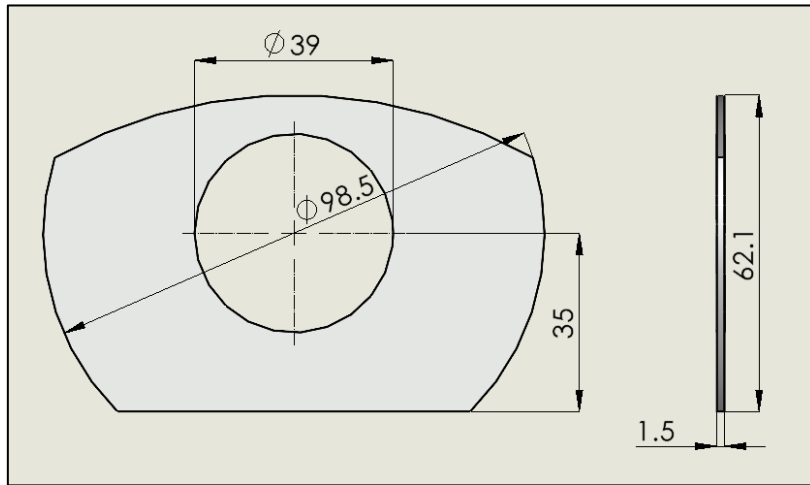

61055 – Camshaft Sintered Bush

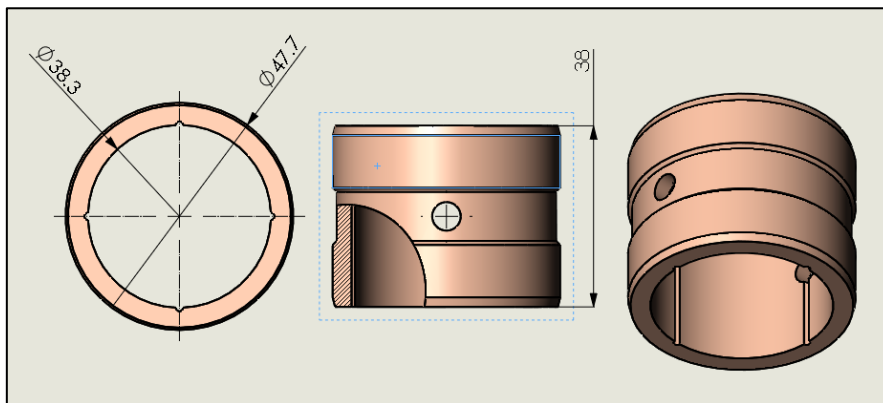

61322A – Hub Cap Pressing

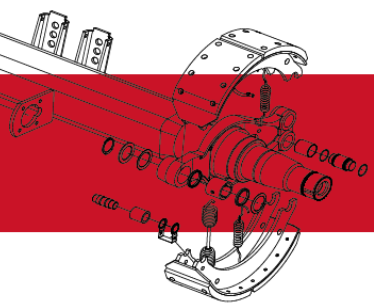
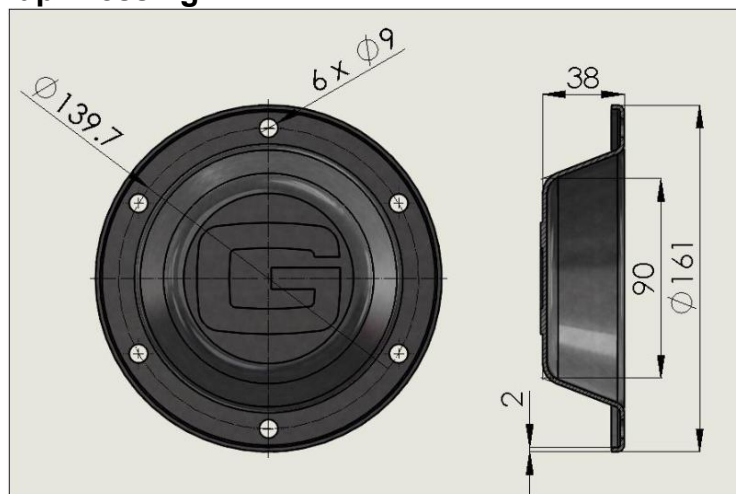

61260F – Inner bearing and cone

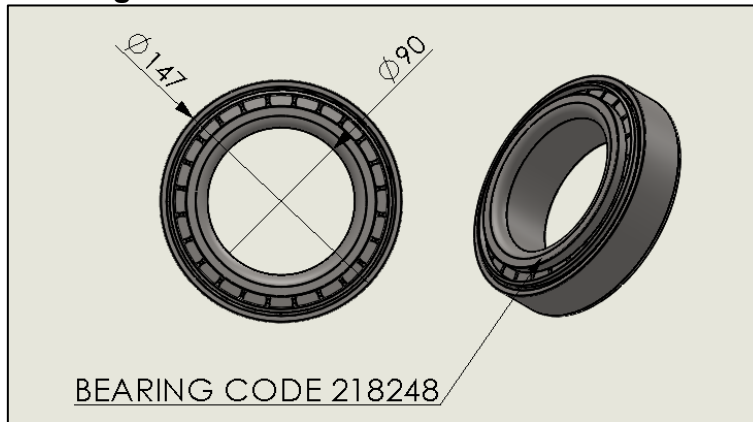

61270F – Outer bearing and cone

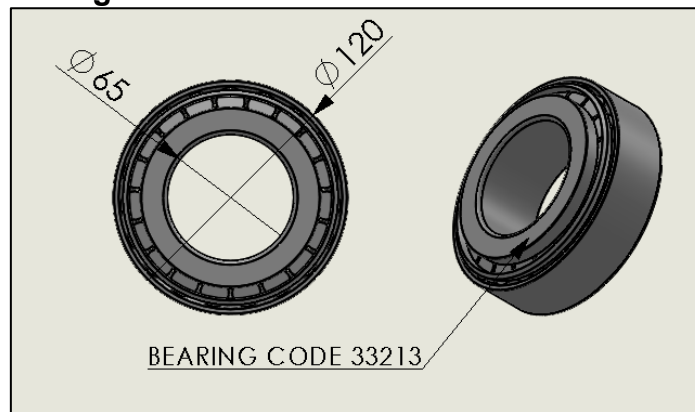

61253 – Hub

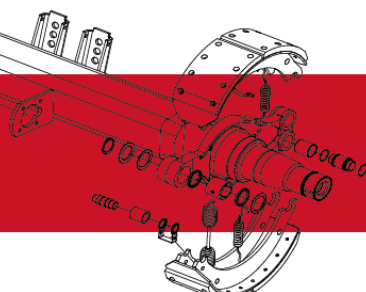
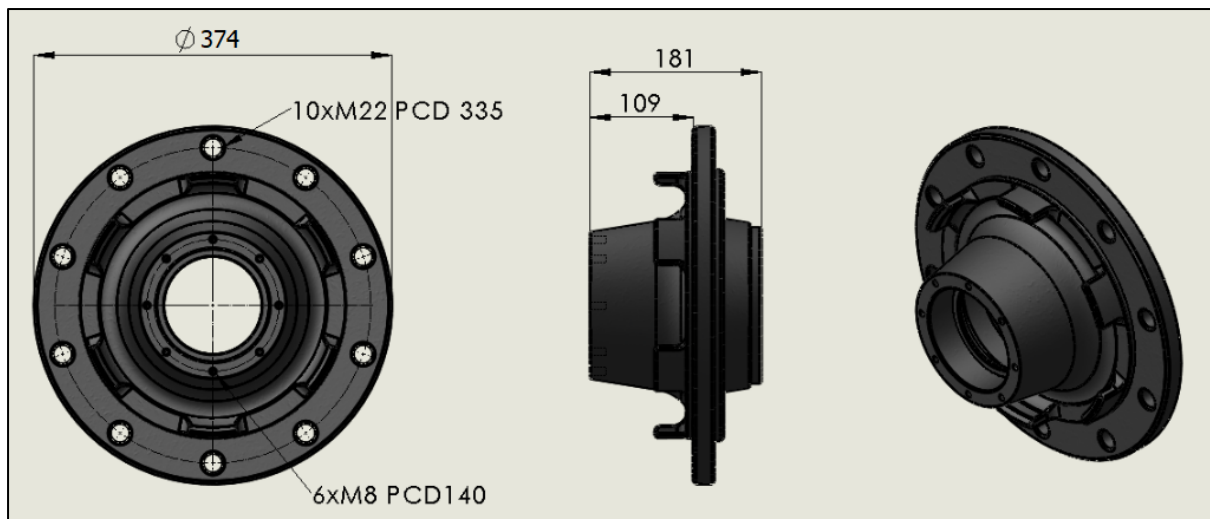

61330F – Gasket

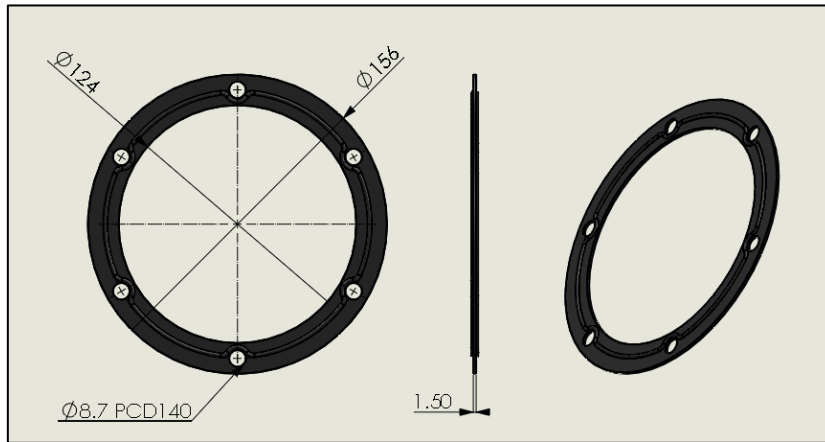

61310 – Locknut

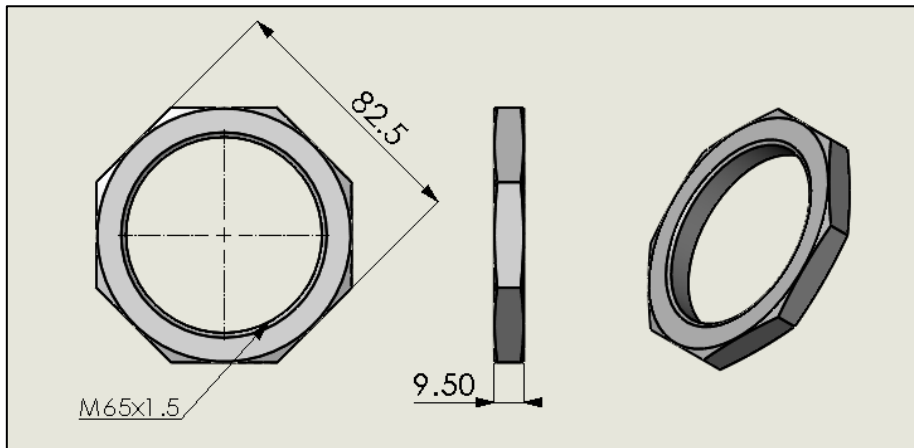

61300 – Lock Washer

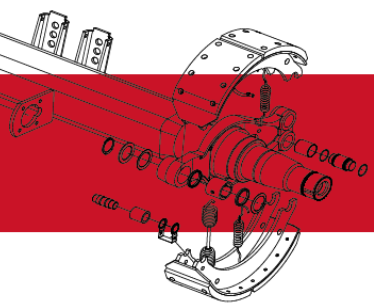
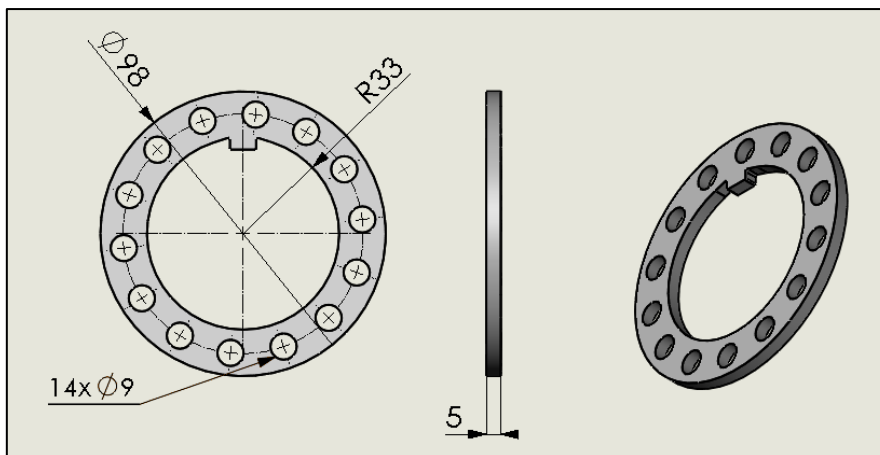

61290 – Adjusting Nut

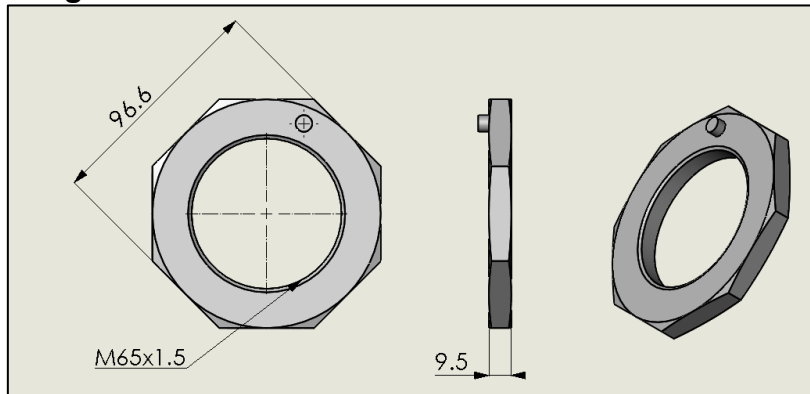

61381Z – ISO M22 Wheel Nut

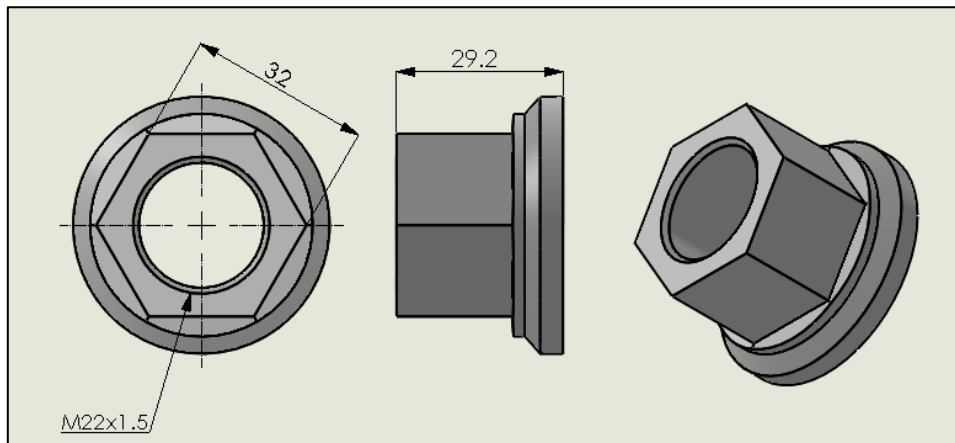

61383 – M22 DIN Wheel Nut + Washers (61372 & 61371)

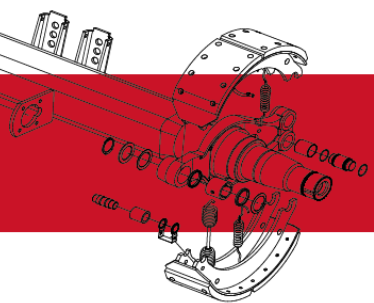
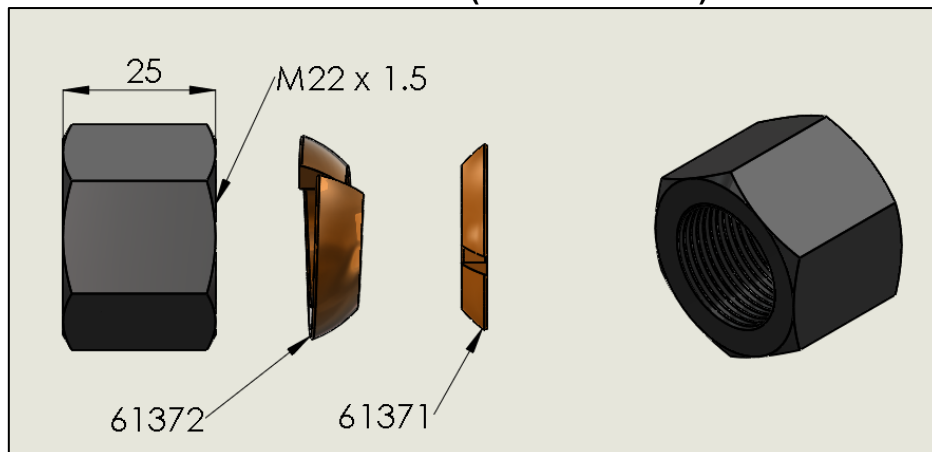

61411 – M22 DIN Wheel Nut

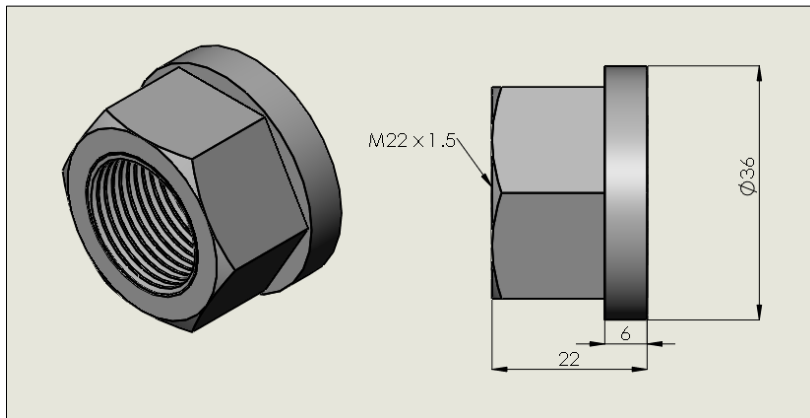

61550A – Brake Drum

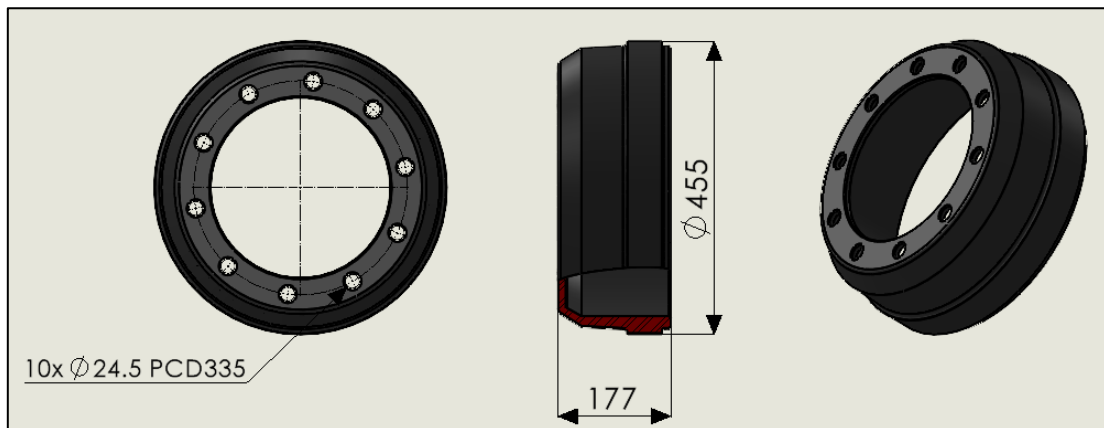

Wheel Bolt

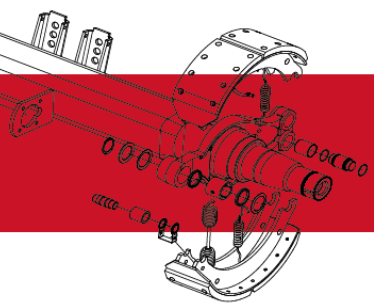
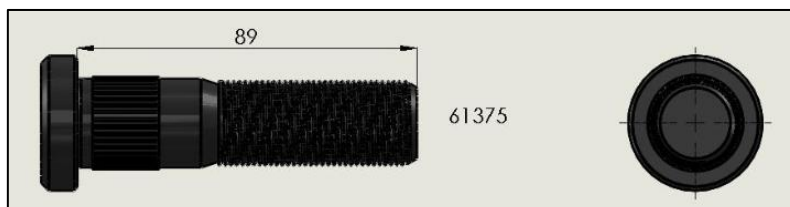
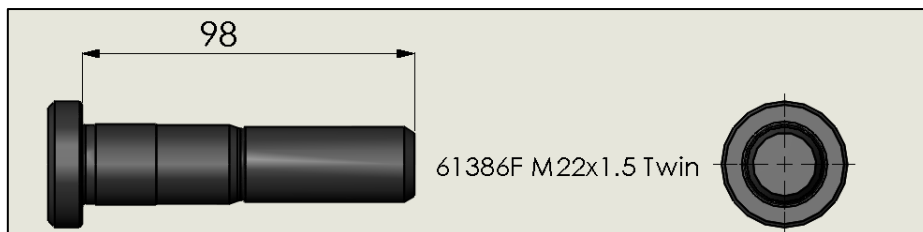

61282F – Unitised Grease Seal

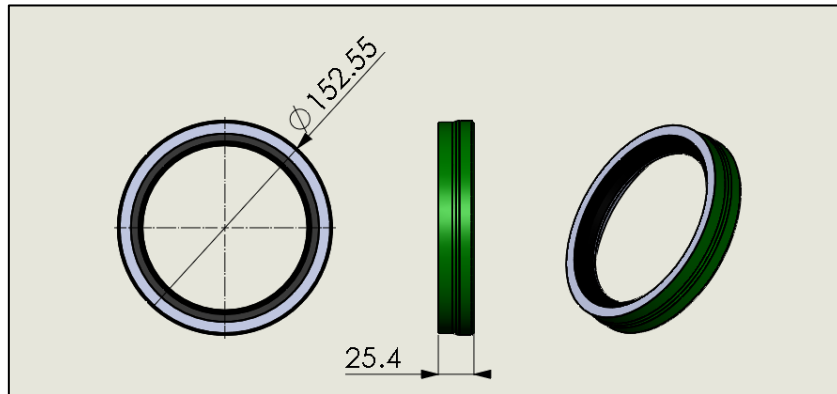

61404A - Dust Cover Spacer

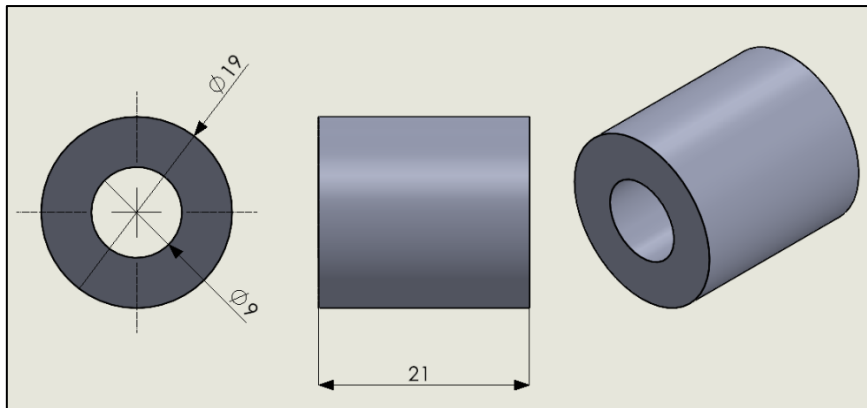

61363A - Dust Cover

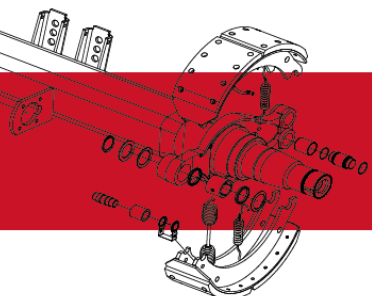
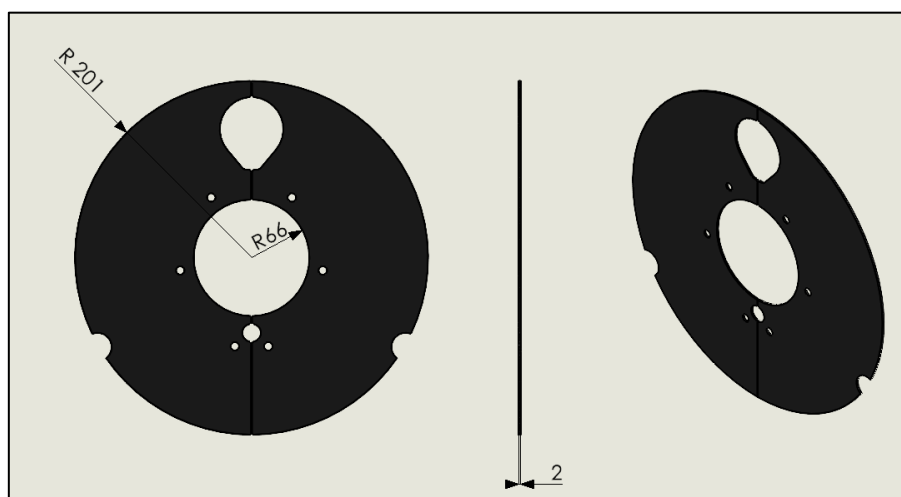

61311 – Tab Washer

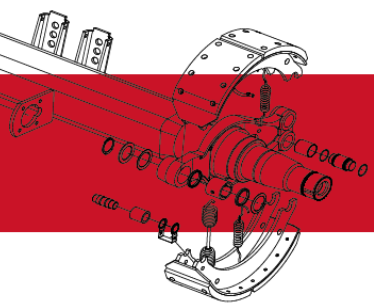
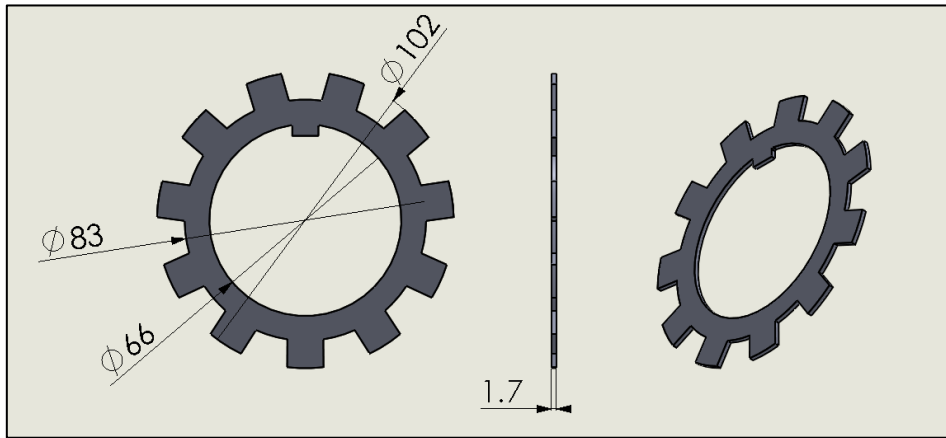

The direction of the grease seals in the anchor bracket is important as well as the position of the beveled washer between the anchor bracket and camshaft head.

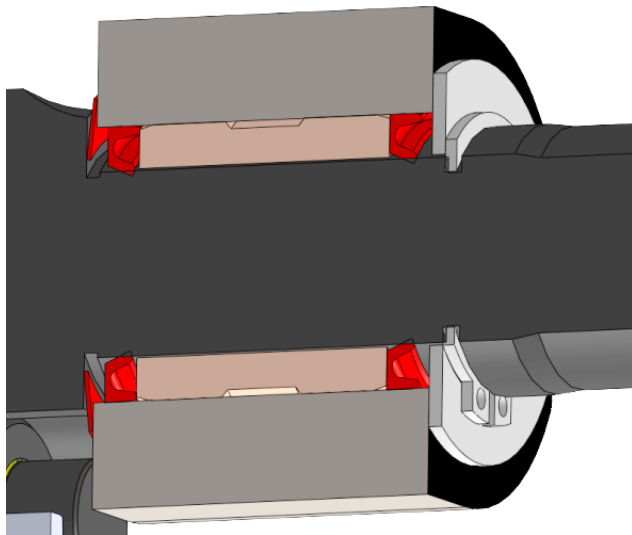
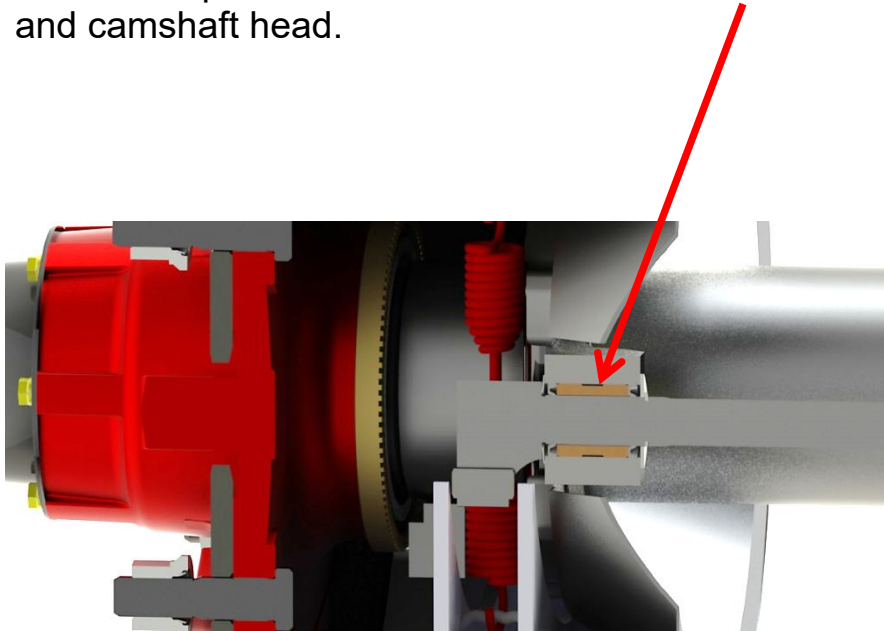

We reserve the right to make changes to specifications or to make improvements to the products in this catalogue without prior notice. We are not responsible for inaccuracies or omissions.

